



UNIVERSITY OF CAMBRIDGE INTERNATIONAL EXAMINATIONS
General Certificate of Education Ordinary Level

DESIGN AND TECHNOLOGY

6043/01

Paper 1 Technology

October/November 2012

2 hours 30 minutes

Additional Materials: Answer Booklet/Paper
 Plain paper
 Sketching equipment



READ THESE INSTRUCTIONS FIRST

Write your Centre number, candidate number and name on all the work you hand in.

Write in dark blue or black pen.

You may use a soft pencil for any diagrams, graphs or rough working.

Do not use staples, paper-clips, highlighters, glue or correction fluid.

Part A

Answer **all** questions.

Part B

Answer **four** questions.

Answer **one** question from Section 1, **two** questions from Section 2, and **one** other question from either Section.

Use sketches where appropriate to help answer any question.

You are advised to spend no longer than 45 minutes on Part A and 1 hour 45 minutes on Part B.

At the end of the examination, fasten all your work securely together.

The number of marks is given in brackets [] at the end of each question or part question.

This document consists of **11** printed pages and **1** blank page.



Part A

You are advised to spend no more than 45 minutes on this part.

Attempt **all** questions.

- 1 Give the names of **three** processed timber boards. [3]
- 2 Fig. 1 shows an artist's palette made from a plastics material.

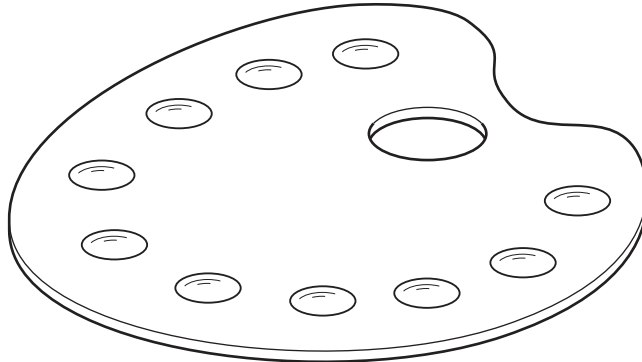
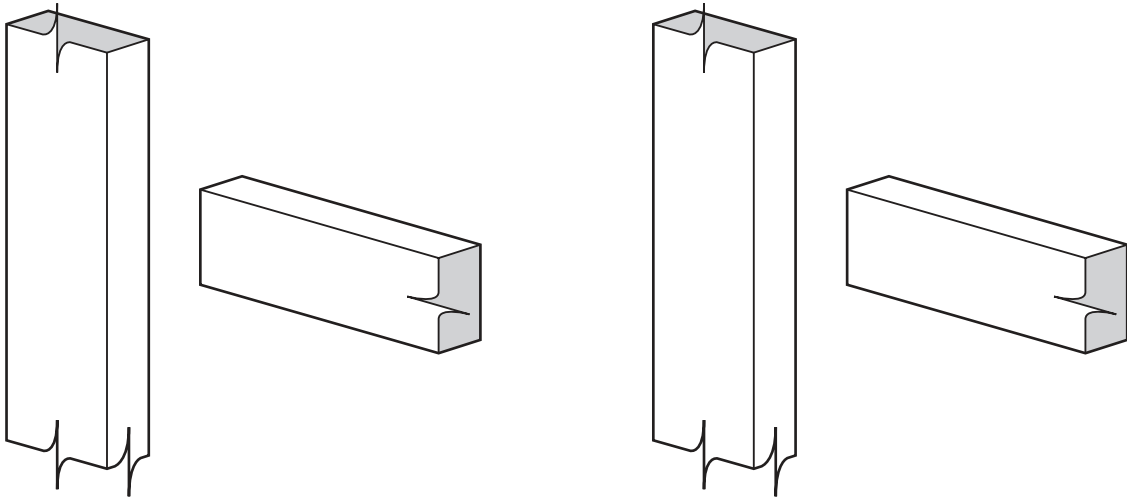

Fig. 1

- Give **two** reasons why plastics are suitable for the palette. [2]
- 3 Give the names of the **two** major metals that are used to make soft solder alloy. [2]
- 4 Copy and complete the outline drawings in Fig. 2 to show the joints named.



(a) Mortice and tenon joint

(b) Dowel joint

Fig. 2

- 5 Explain what is meant by the term *realisation* in the design process. [4]

[3]

- 6 State a suitable plastics material for each of the situations shown in Fig. 3.

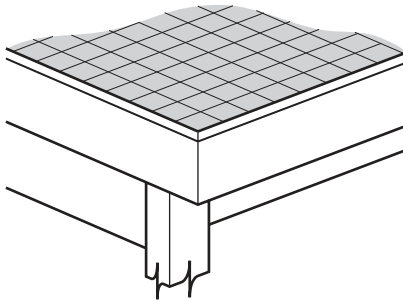

(a) Hard wearing surface for a table top

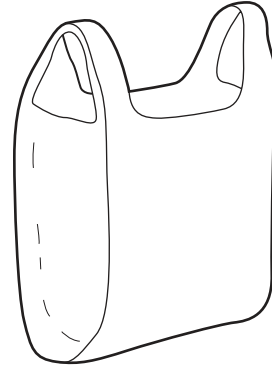

(b) Bag for holding shopping

Fig. 3

[2]

- 7 State **three** details that would be needed when ordering wood screws for a project. [3]

- 8 Fig. 4 is a diagram used to explain a plastics forming process.

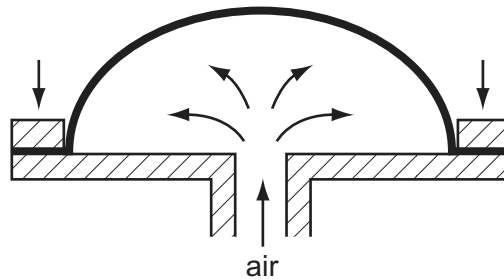

Fig. 4

- (a) Name the process. [1]

- (b) What must be done to the plastic in order for it to be formed? [1]

- 9 Explain why a lubricant is used when cutting a thread on metal. [2]

- 10 Name the tools shown in Fig. 5 and give a specific use for each. [4]

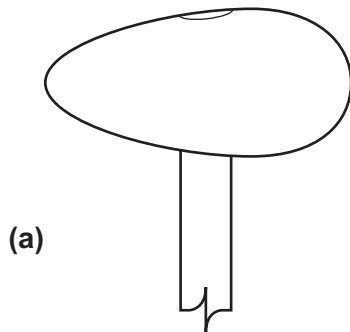

(a)

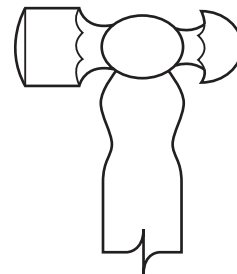

(b)

Fig. 5

[4]

Part B

You are advised to spend at least 1 hour 45 minutes on this part of the examination.

Attempt **four questions** including **one** from Section 1, **two** from Section 2 and **one** further question from either section.

All questions carry equal marks.

Section 1 - Tools and Materials

- 11** Potential risks should always be considered when working material or using tools.
- (a)** Using a different example in each case, explain how working some materials could result in:
- (i)** breathing problems;
 - (ii)** eye problems;
 - (iii)** skin problems. [9]
- (b)** State **three** types of protective clothing or equipment available in the school workshop and give the reasons for the use of each. [6]
- (c)** Explain why it can be dangerous to use badly maintained tools. [2]

12 Fig. 6 shows three different cutting tools.

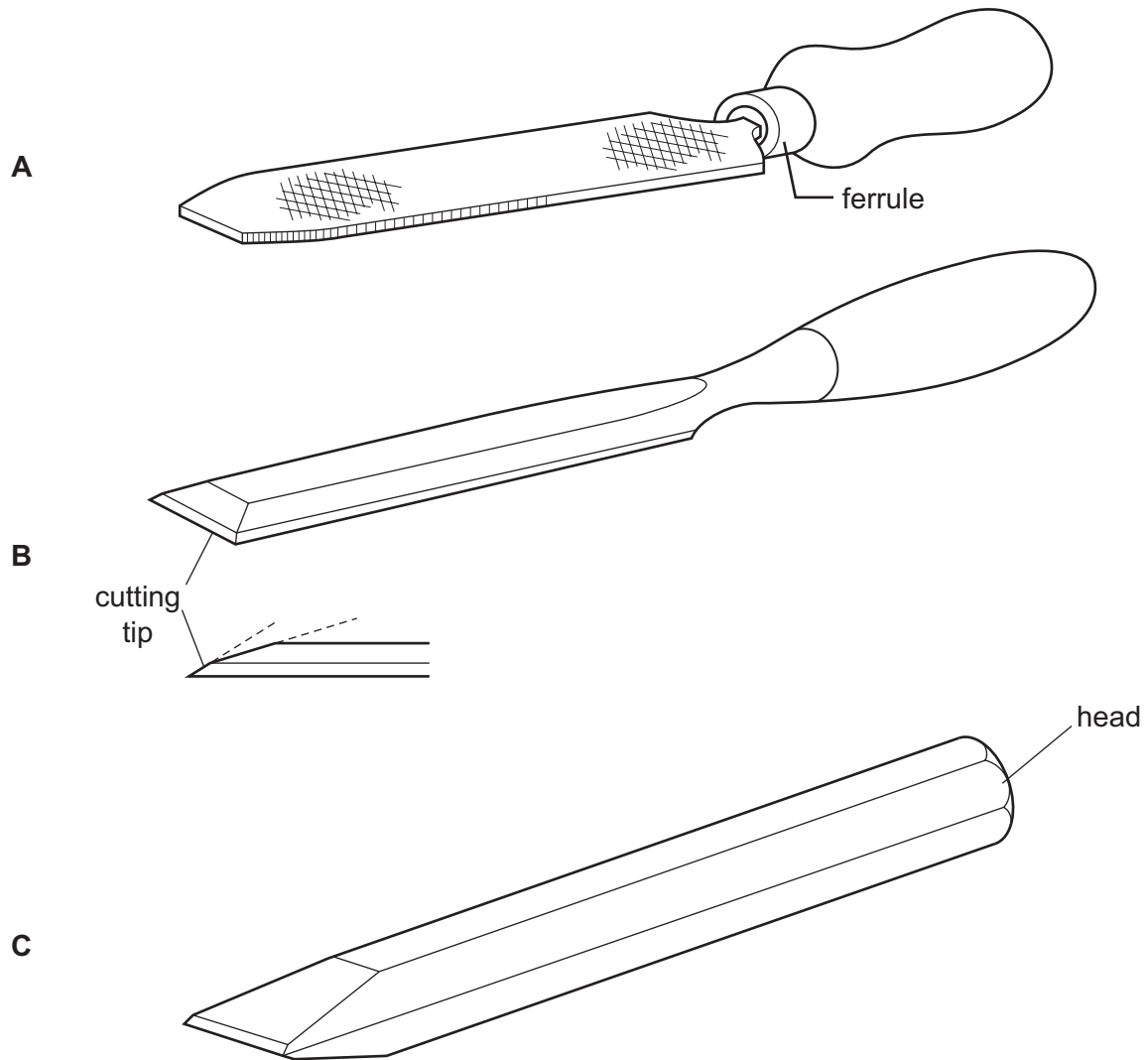

Fig. 6

- (a) Name each tool and state its purpose. [6]
- (b) Explain the reason for:
- (i) the steel ferrule on tool **A**;
 - (ii) two different angles on the tip of tool **B**;
 - (iii) the head of tool **C** being left in a soft state. [6]
- (c) With the aid of sketches, explain why work to be cut by the three tools needs to be held in some way. [5]

- 13 Fig. 7 shows an idea for a puzzle that is made up of six interlocking pieces that join together to form a disc.

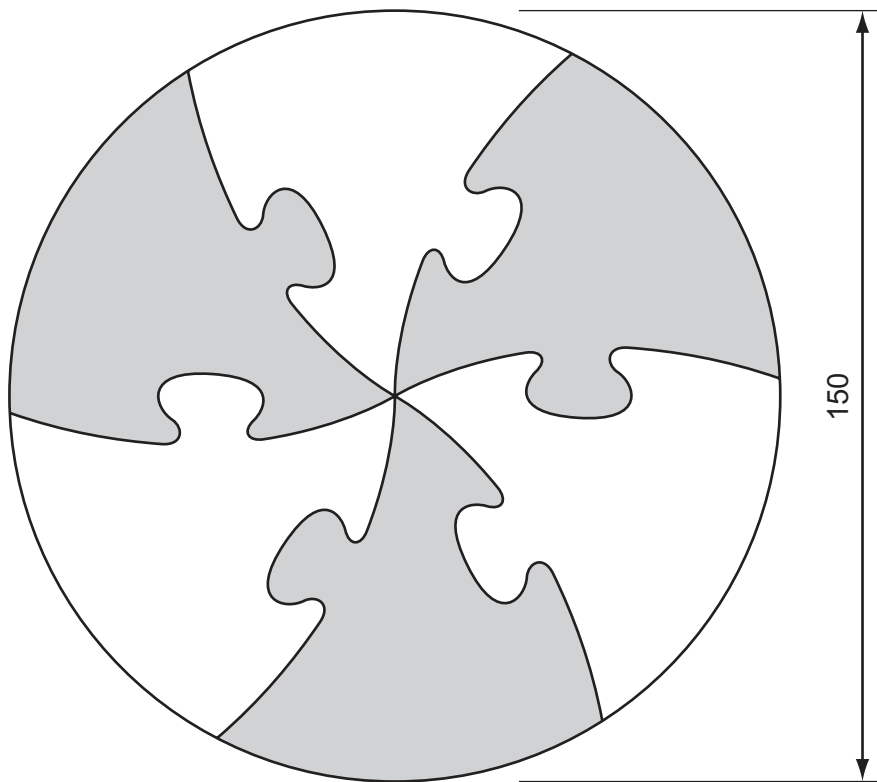

Fig. 7

- (a) Some possible materials being considered for the puzzle are listed below. For each, give one reason for selection and one reason for rejection.
- (i) acrylic
 - (ii) aluminium
 - (iii) plywood
- [6]
- (b) Explain why it is better to cut the pieces from a prepared disc than to make each piece separately.
- [2]
- (c) Select **one** of the materials from (a) and sketch a suitable tool for:
- (i) marking out the disc;
 - (ii) holding the disc while being worked;
 - (iii) cutting out the pieces.
- [9]

Section 2 - Processes

14 Parts of a washroom shelf unit are shown in Fig. 8.

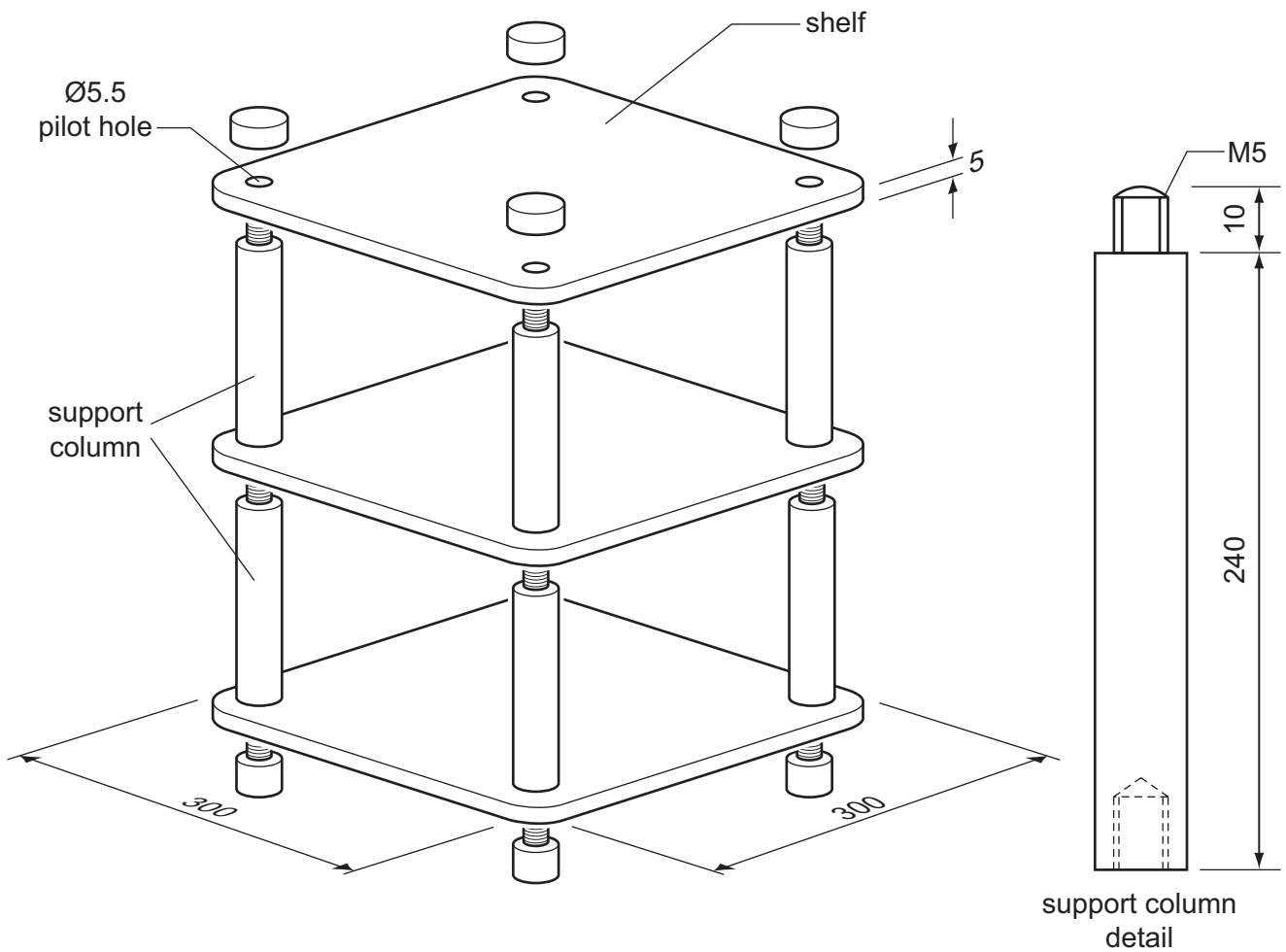

Fig. 8

- (a) Give **two** properties that any material should have to be suitable for the unit. [2]
- (b) Using a material of your choice, describe, with the aid of notes and sketches:
- (i) marking out positions and drilling of holes in shelves;
 - (ii) making the shelf support columns. [15]

15 Fig. 9 gives details of the letter R from a display of lettering.

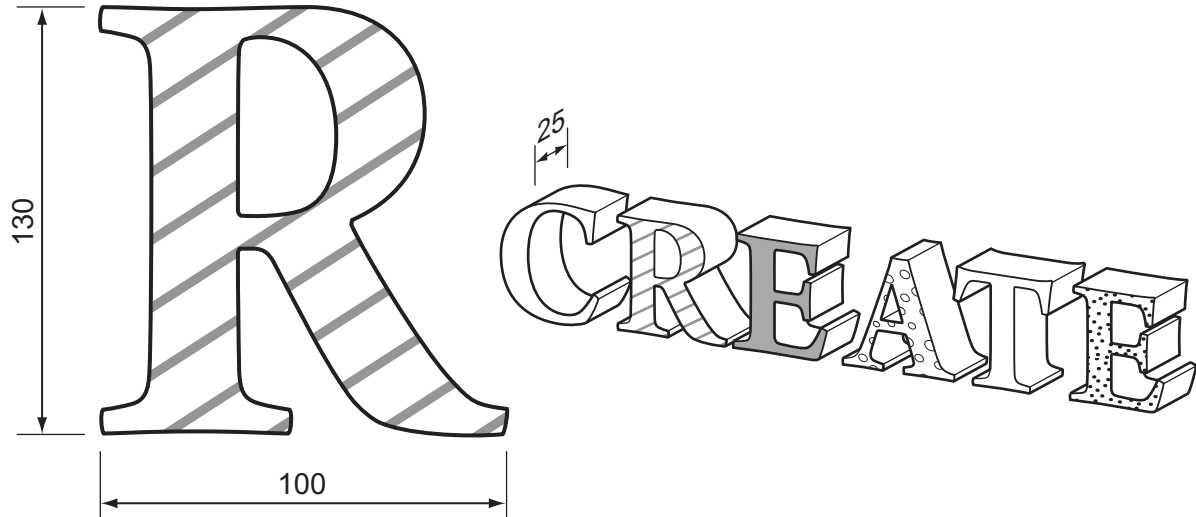

Fig. 9

- (a) Suggest **two** possible methods of production for the letter R and give **one** reason why each would be suitable. [4]
- (b) Choose **one** of the methods you have suggested in (a) and, using notes and sketches, describe the **major** stages in making the letter R. [10]
- (c) Describe, with the aid of sketches, how the decorative angled lines may be applied to the surface of the letter R. [3]

16 Details of an end support from a spice jar rack are shown in Fig. 10.

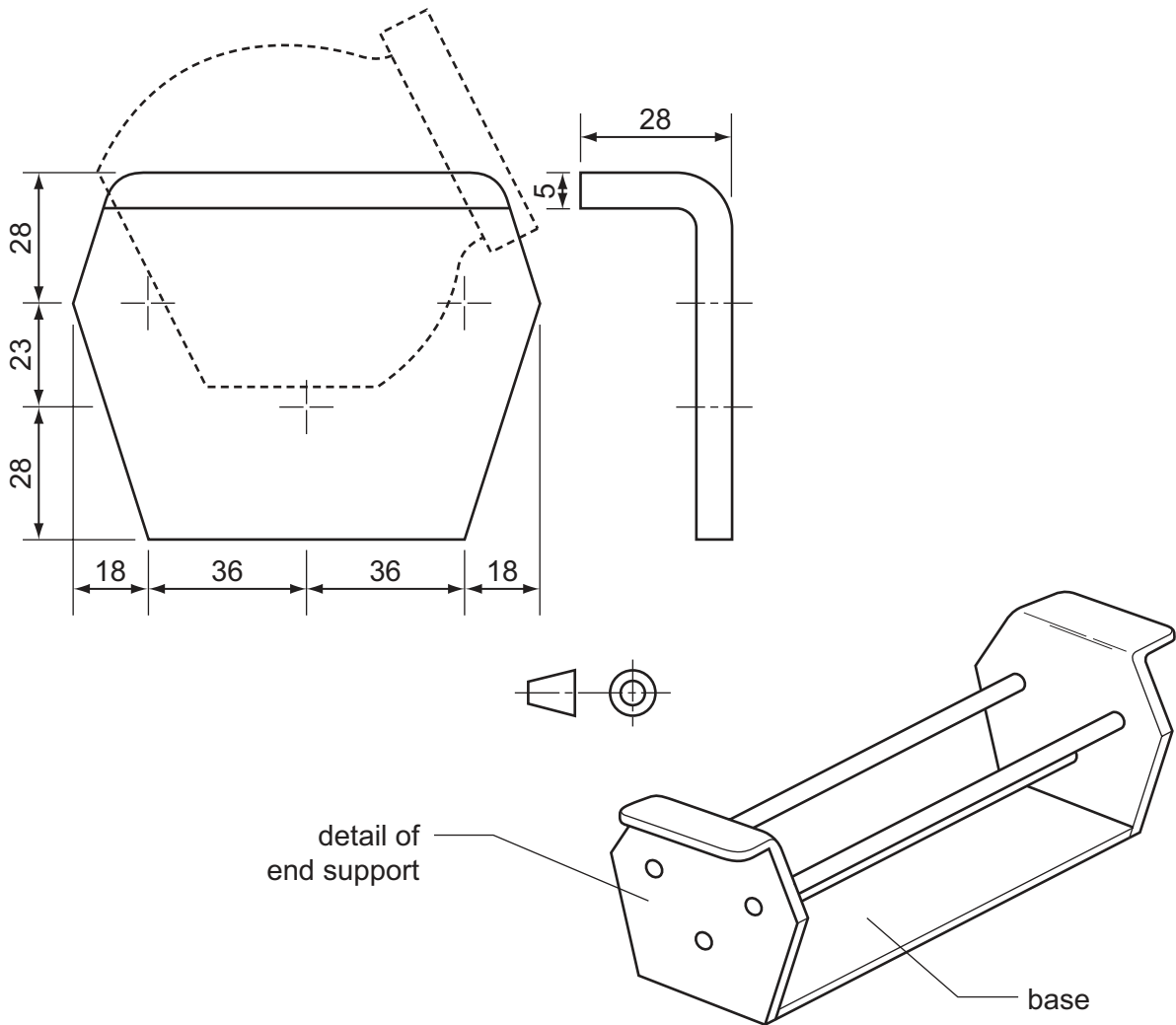
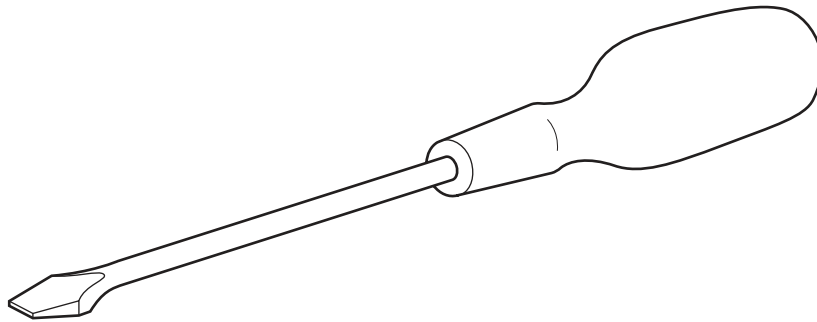

Fig. 10

- (a) Suggest a suitable sheet material for the end support and give a reason for your choice. [2]
- (b) Using the material chosen in (a), describe, with the aid of notes and sketches, each of the following processes:
- (i) marking out the shape and hole positions;
 - (ii) cutting to shape;
 - (iii) forming the bend. [12]
- (c) With the aid of sketches, show how the end support could be fixed to the base. [3]

17 Choose **two** of the processes in Fig. 11 and, using notes and sketches, describe how each is carried out.

(a) Hardening and tempering the tip of a screwdriver blade



(b) Plastic dip coating a cast-iron door handle

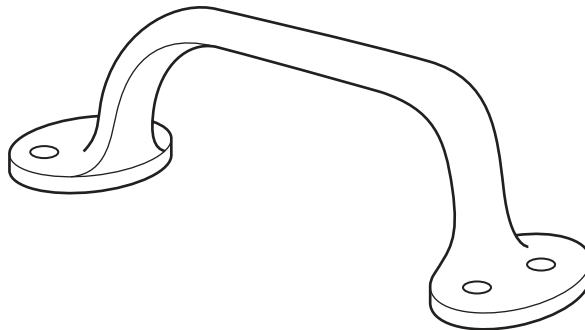

(c) Marking out and cutting a single dovetail joint

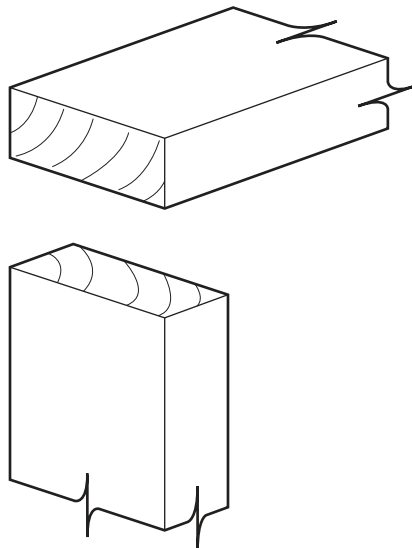

Fig. 11

[17]

18 Details of a small bangle are given in Fig. 12.

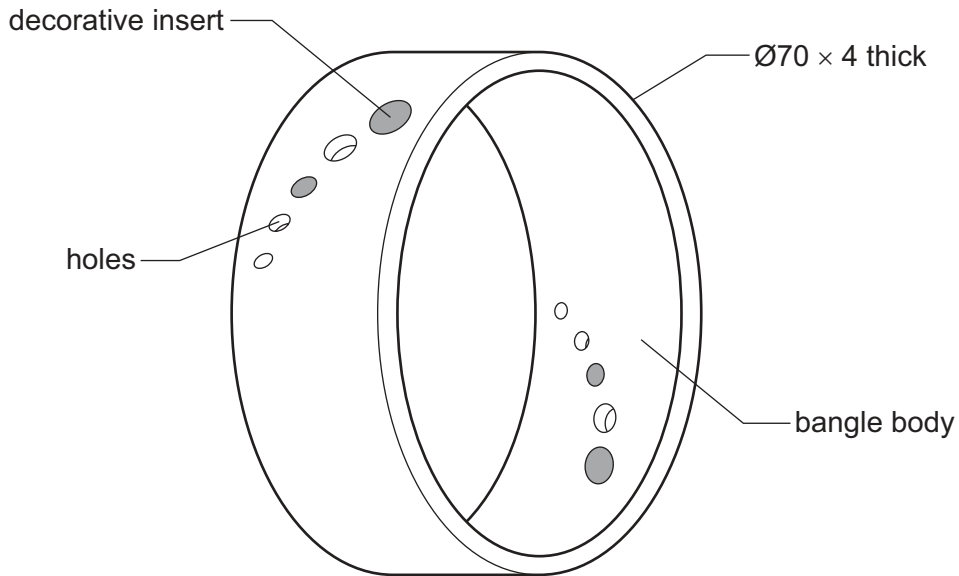

Fig. 12

- (a) Suggest a suitable material for the bangle and give a reason why it would be suitable. [2]
- (b) Using the material chosen in (a), describe, with the aid of notes and sketches, each of the following processes.
- (i) production of the bangle body [9]
- (ii) drilling the holes [4]
- (c) Choose a colourful material for the decorative insert and describe how it would be fixed to the bangle. [2]

Permission to reproduce items where third-party owned material protected by copyright is included has been sought and cleared where possible. Every reasonable effort has been made by the publisher (UCLES) to trace copyright holders, but if any items requiring clearance have unwittingly been included the publisher will be pleased to make amends at the earliest possible opportunity.

University of Cambridge International Examinations is part of the Cambridge Assessment Group. Cambridge Assessment is the brand name of University of Cambridge Local Examinations Syndicate (UCLES), which is itself a department of the University of Cambridge.